

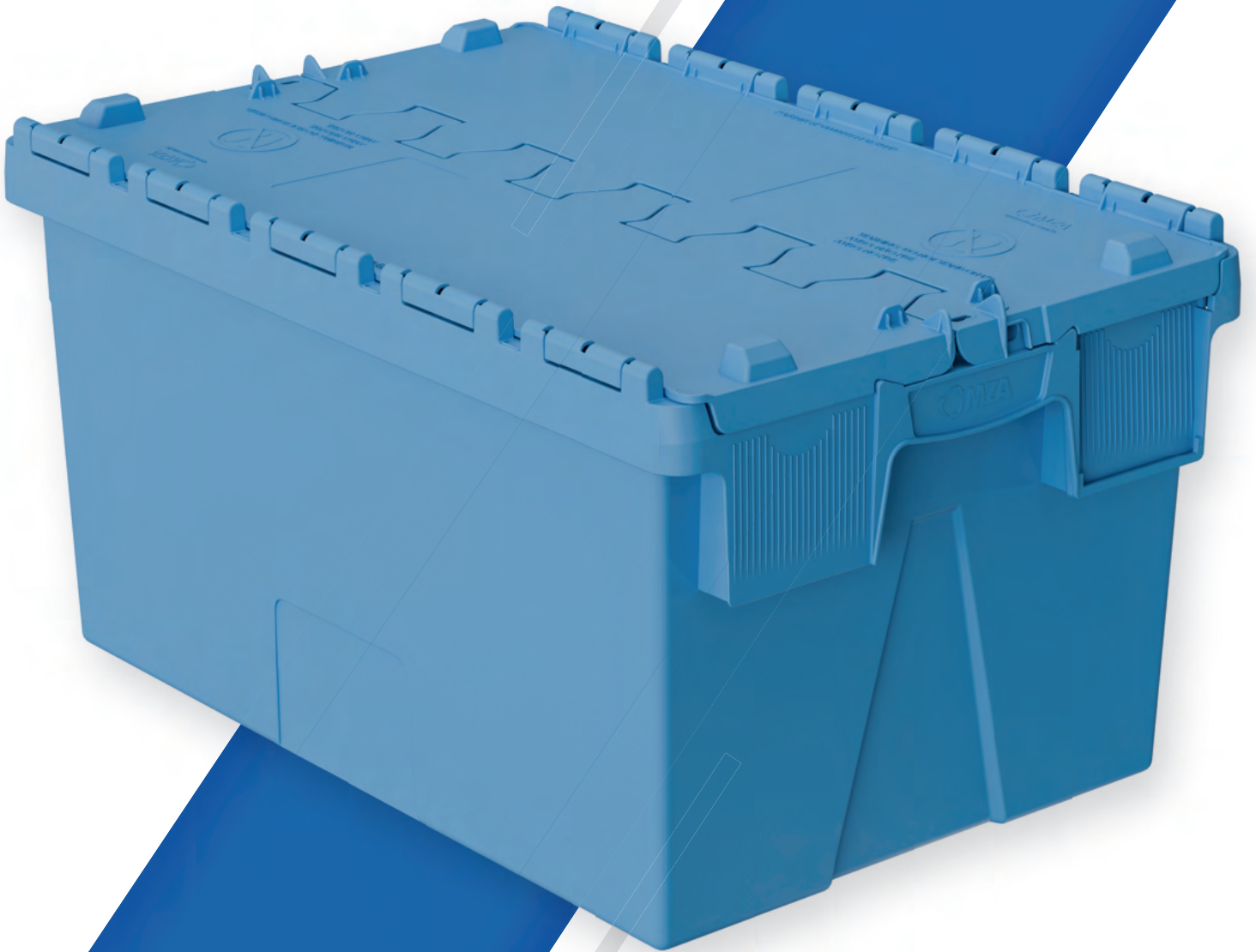

Material Handling Packaging Solutions



PRODUCT
CATALOG

2024

Line ARKA ALC

FEATURES:

Plastic box with integrated lid. On the smaller faces, there is a space reserved for the application of self-adhesive labels, while the larger faces can accommodate labels with barcodes. Allows for the placement of tamper-evident seals with the lids closed. The lid is adapted for the use of strapping bands, providing increased security. It also features a 63% volume reduction in return stacking, making it an economical and convenient option for cargo transport. Both the box and the lid can be produced in various colors to meet customer preferences.

APPLICATIONS:

- Cash transportation
- Pharmaceutical industry
- E-commerce
- Object transportation

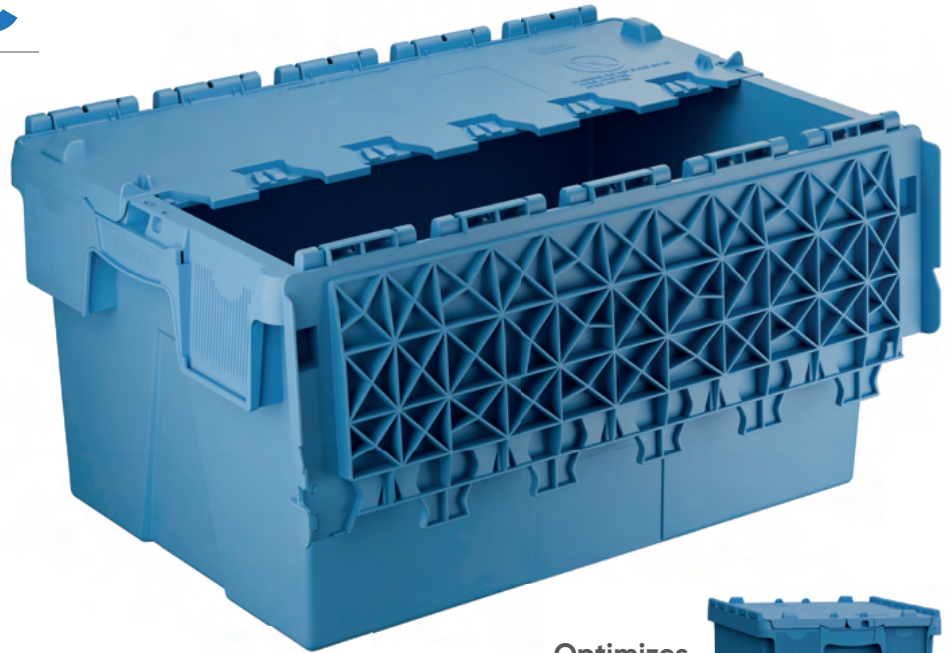

LABEL HOLDER

For better identification of boxes in logistics.



SECURITY SEAL

System that guarantees inviolability.

Optimizes space by up to 70% in reverse logistics.



ARKA ALC LINE	NOMINAL DIMENSIONS length x width x height (in)	EXTERNAL DIMENSIONS length x width x height (in)	INTERNAL DIMENSIONS TOP length x width (in)	INTERNAL DIMENSIONS BASE length x width (in)	USEFUL INTERNAL HEIGHT DIMENSIONS (in)	WEIGHT (lbs)	CAPACITY (ft³)	MATERIAL
2110	7,87x5,12x3,94	7,09x5,12x3,94	5,75x4,37	5,08x3,62	3,46	0,4	0,04	PP
3222	11,81x7,87x8,66	11,85x7,64x8,66	9,65x6,26	8,74x5,16	7,87	1,9	0,23	PP
4328	15,75x11,81x11,02	15,87x11,73x11,02	13,58x10,35	12,20x8,74	10,24	3,5	0,74	PP
5321	19,69x11,81x8,27	19,41x11,82x8,27	17,72x10,87	16,42x9,49	6,30	4,1	0,71	PP
5327	19,69x11,81x10,63	19,41x11,89x10,35	17,72x10,87	16,06x9,09	8,39	4,4	0,85	PP
5328	19,69x11,81x11,02	19,88x11,81x11,02	17,52x10,43	16,22x9,61	10,24	4,6	1,02	PP
5334	19,69x11,81x13,39	20,47x12,60x13,54	18,11x11,42	16,93x10,43	12,79	5,7	1,43	PP
6425	23,62x15,75x9,84	23,86x15,63x9,84	21,50x14,57	20,28x13,78	9,07	5,9	1,55	PP
6432	23,62x15,75x12,60	23,98x15,63x12,60	21,50x14,57	20,28x13,58	11,83	6,6	2,01	PP
6437	23,62x15,75x14,57	23,86x15,63x14,37	21,50x14,57	20,04x13,50	13,60	6,8	2,26	PP
6440	23,62x15,75x15,75	23,62x15,75x15,75	21,65x14,29	19,69x12,28	14,43	6,8	2,40	PP
6545	23,62x19,69x17,72	23,98x19,69x17,72	21,46x18,62	19,76x17,28	16,79	10,1	3,64	PP

Line R-KLT

FEATURES:

An industrial box that streamlines handling, transportation, and storage within the logistics chain. The inner face of the bottom is completely smooth to facilitate automated loading and unloading of the contents. It has an optional space for placing identification cards (VDA 4902 standard - 210 x 75 mm) and a textured space for placing self-adhesive labels. Allows for sealing when used with a lid and accommodates all movements of different material flow systems.

APPLICATIONS:

Automotive industry
Metalworking industry
General industry

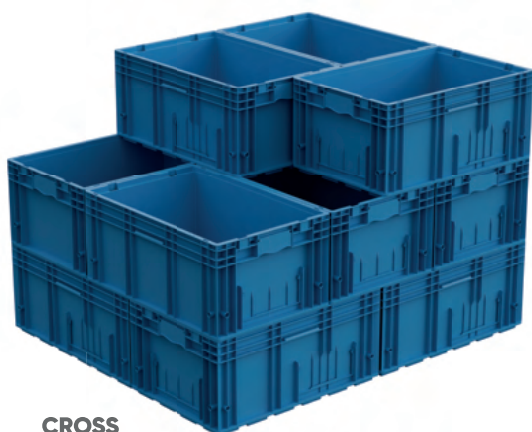

CROSS STACKING



LABEL HOLDER

For better identification of boxes in logistics.

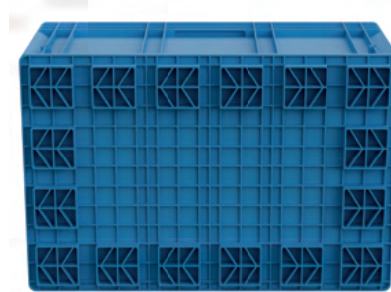

LEGO BOTTOM

R-KLT 3215 R-KLT 4315 R-KLT 4322 R-KLT 4329 R-KLT 6415 R-KLT 6421 R-KLT 6429



R-KLT 6429C R-KLT 6428 R-KLT 6428C R-KLT 6432 R-KLT 6432C PARTITIONS LABEL HOLDER



COVER



R-KLT LINE	NOMINAL DIMENSIONS length x width x height (in)	EXTERNAL DIMENSIONS length x width x height (in)	INTERNAL DIMENSIONS TOP length x width (in)	INTERNAL DIMENSIONS BASE length x width (in)	USEFUL DIMENSIONS INTERNAL HEIGHT DIMENSIONS (in)	WEIGHT (lbs)	CAPACITY (ft ³)	MATERIAL
3215	11,81x7,87x5,79	11,57x7,80x5,81	9,84x6,65	9,57x6,38	4,33	1,54	0,16	PP
4315	15,75x11,81x5,79	15,59x11,69x5,81	13,70x10,51	13,58x10,39	4,33	2,8	0,32	PP
4322	15,75x11,81x8,27	15,59x11,69x8,27	14,25x10,35	14,02x10,12	6,65	3,3	0,55	PP
4329	15,75x11,81x11,02	15,59x11,69x11,02	14,25x10,35	13,90x10,0	9,41	3,9	0,78	PP
6415	23,62x15,75x5,79	23,39x15,59x6,10	21,42x14,33	21,10x14,02	4,61	5,07	0,81	PP
6421	23,62x15,75x8,27	23,39x15,59x8,27	21,42x14,33	21,10x13,98	6,77	5,7	1,18	PP
6429	23,62x15,75x11,02	23,39x15,59x11,02	21,42x14,33	21,18x14,09	9,53	6,6	1,66	PP
6429C (CUSTOM)	23,62x15,75x11,02	23,39x15,59x11,02	21,42x14,33	21,18x14,09	9,53	6,3	0,88	PP
N-KLT 6428	23,62x15,75x11,02	23,39x15,59x11,02	22,20x14,41	22,01x14,21	9,72	5,5	1,78	PP
N-KLT 6428C	23,62x15,75x11,02	23,39x15,59x11,02	22,20x14,41	22,01x14,21	9,72	5,7	0,88	PP
N-KLT 6432	23,62x15,75x12,60	23,39x15,59x12,60	22,20x14,41	22,01x14,21	11,30	6,1	2,07	PP
N-KLT 6432C	23,62x15,75x12,60	23,39x15,59x12,60	22,20x14,41	22,01x14,21	11,30	6,1	1,16	PP

Line **EURO FORTE**

FEATURES:

An industrial box that streamlines handling, transportation, and storage within the logistics chain. The inner face of the bottom is completely smooth to facilitate the automated loading and unloading of contents. Additionally, it accommodates all movements of different material flow systems and allows for sealing when used with a lid. It features a textured space for placing self-adhesive labels.

APPLICATIONS:

- Cash transportation
- Pharmaceutical industry
- E-commerce
- Object transportation

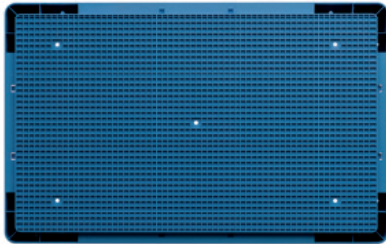

**REINFORCED
BOTTOM**



3210

4320

7420



EURO FORTE LINE	NOMINAL DIMENSIONS length x width x height (in)	EXTERNAL DIMENSIONS length x width x height (in)	INTERNAL DIMENSIONS TOP length x width (in)	INTERNAL DIMENSIONS BASE length x width (in)	USEFUL INTERNAL HEIGHT DIMENSIONS (in)	WEIGHT (lbs)	CAPACITY (ft³)	MATERIAL
3210	11,81x27,87x3,94	14,96x9,45x4,13	13,31x8,50	13,07x7,56	3,50	1,54	0,21	PP
4320	15,75x11,81x7,87	18,90x14,17x7,87	17,28x13,35	16,93x12,99	7,28	4,1	0,99	PP
7420	27,56x15,75x7,87	29,92x18,90x7,87	28,35x17,32	27,95x16,93	7,28	6,8	2,15	PP

Line TOTE

FEATURES:

An industrial box that streamlines handling, transportation, and storage within the logistics chain. Developed for various applications, it is used for stock maintenance in logistic warehouses – SKU (Stock Keeping Unit) and also in automatic/semi-automatic systems for order picking.

APPLICATIONS:

Storage in distribution centers
Stock maintenance
Automated systems



**CROSS
STACKING**

**ACCESS
DOOR**



TOTE LINE	NOMINAL DIMENSIONS <small>length x width x height (in)</small>	EXTERNAL DIMENSIONS <small>length x width x height (in)</small>	INTERNAL DIMENSIONS TOP <small>length x width (in)</small>	INTERNAL DIMENSIONS BASE <small>length x width (in)</small>	USEFUL INTERNAL HEIGHT DIMENSIONS (in)	WEIGHT (lbs)	CAPACITY (ft ³)	MATERIAL
CP 5322	19,69x11,81x7,87	17,72x11,81x7,87	16,46x10,91	13,74x10,91	4,40	2,6	0,35	PP
CP 5321	19,69x11,81x8,27	19,41x11,89x8,27	17,72x10,87	16,42x9,49	6,30	1,2	0,71	PP
CP 5327	19,69x11,81x0,85	19,41x11,89x10,35	17,72x10,87	16,06x9,09	8,39	3	0,85	PP
CP 6423	23,62x15,75x8,66	23,62x15,55x9,06	21,30x14,13	8,74x5,16	8,46	4,1	1,41	PP
CF 6423	23,62x15,75x9,06	23,62x15,55x9,06	21,50x14,13	20,63x13,46	8,46	4,4	1,41	PP
CP 6432	23,62x15,75x12,60	23,62x15,55x15,52	21,54x14,17	20,20x13,11	11,81	5,2	1,98	PP
CF 6432	23,62x15,75x12,60	23,62x15,55x12,52	21,54x14,17	20,20x13,11	11,81	5,5	1,98	PP
CPF 6430	23,62x15,75x11,81	23,62x15,75x11,81	20,83x14,96	20,24x14,09	10,96	5,07	2,01	PP
CPV 6430	23,62x15,75x11,81	23,62x15,75x11,81	20,83x14,96	20,24x14,09	11,83	4,8	2,01	PP
CPR 6432	23,62x15,75x12,60	24,41x17,72x12,60	22,68x16,38	20,71x14,41	12,40	5,7	2,42	PP
CPF 6427	23,62x15,75x10,63	23,62x15,75x10,63	20,28x14,45	19,33x13,50	9,84	4,1	1,60	PEAD / PP
CP 6428	23,62x15,75x11,02	23,39x15,59x11,02	22,20x14,41	21,85x14,06	10,31	5,07	0,99	PP
CPC 6432	23,62x15,75x12,60	23,39x15,59x12,60	22,20x14,41	21,85x14,06	11,89	5,7	1,27	PP
CPF 6428	23,62x15,75x11,02	23,39x15,59x11,02	22,20x14,41	22,01x14,21	9,72	6,1	1,87	PP
CPF 6432	23,62x15,75x12,60	23,39x15,59x12,60	22,20x14,41	22,01x14,21	11,89	5,9	2,25	PP
CP 7323	27,56x11,81x9,06	27,56x12,20x9,06	27,32x10,87	25,98x10,28	8,98	5,1	1,62	PP

Line **FLEX F-KLT**

FEATURES:

Developed according to the automotive VDA 4500 standard, FLEX F-KLT boxes feature high strength and standardization. They have been specially designed to solve the main transportation and storage problems of autonomous industrial and pharmaceutical sectors.

APPLICATIONS:

Cash transportation
Pharmaceutical industry
E-commerce



COLLAPSIBLE



PLAIN BOTTOM



LEGO BOTTOM

6421.G

6421

6428.G

6428

COVER



F-KLT LINE	NOMINAL DIMENSIONS length x width x height (in)	EXTERNAL DIMENSIONS length x width x height (in)	USEFUL INTERNAL HEIGHT	COLLAPSED DIMENSION (in)	WEIGHT (LBS)	CAPACITY (ft ³)	MATERIAL
6421.G (FUNDO LISO)	23,69x15,75x8,27	23,31x14,37x8,27	7,56	3,74	5,9	1,39	PP
6421 (FUNDO LEGO)	23,62x15,75x8,27	23,31x14,37x8,27	6,77	3,74	6,3	1,25	PP
6428.G (FUNDO LISO)	23,62x15,75x11,02	23,31x14,37x11,02	10,35	3,74	6,3	1,76	PP
6428 (FUNDO LEGO)	23,62x15,75x11,02	23,31x14,37x11,02	9,57	3,74	7,27	1,63	PP

Line **GLT HÉRCULES**

FEATURES:

The finest line of boxes in the United States following the VDA-GLT standard, which can be moved using pallet jacks or forklifts and stored directly on shelves. Its innovative design blends simplicity and robustness, along with high-quality materials ensuring high resistance. For further optimization, use the Hercules box extender.

APPLICATIONS:

Storage in distribution centers
Stock maintenance
General industries

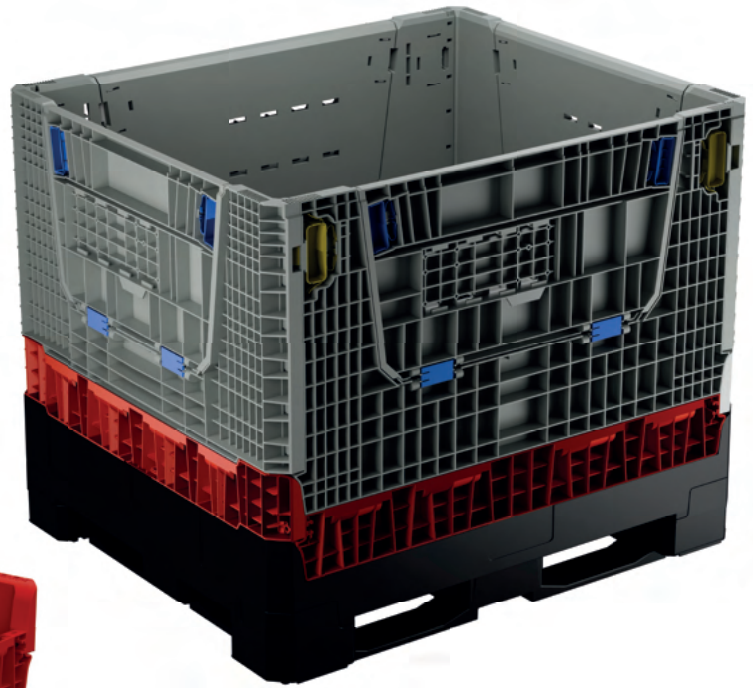

EXTENDER

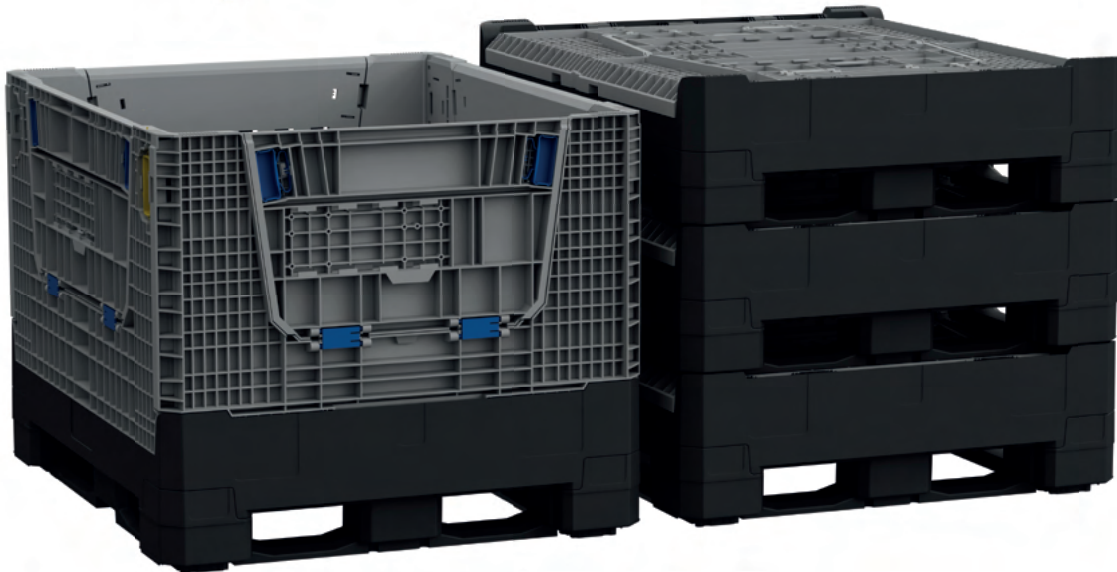
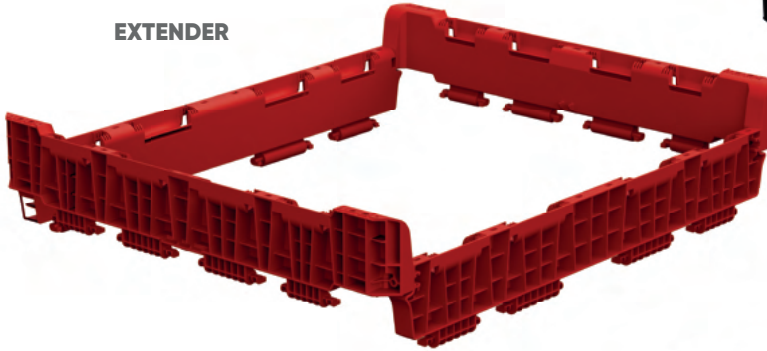

121065

121086

121010

COVER



GLT LINE	NOMINAL DIMENSIONS length x width x height (in)	EXTERNAL DIMENSIONS length x width x height (in)	INTERNAL DIMENSIONS TOP length x width (in)	INTERNAL DIMENSIONS BASE length x width (in)	USEFUL INTERNAL HEIGHT DIMENSIONS (in)	WEIGHT (lbs)	CAPACITY (ft ³)	MATERIAL
121065	47,24x39,37x25,59	47,24x39,37x25,59	44,09x36,22	44,09x36,22	18,27	110	16,88	PP
121086	47,24x39,37x33,86	47,24x39,37x33,86	44,09x36,22	44,09x36,22	26,54	132	24,51	PP
121010	47,24x39,37x39,37	47,24x39,37x39,37	44,09x36,22	44,09x36,22	32,05	154	29,66	PP

Line PALLET

FEATURES:

Highly resistant pallet that withstands weather conditions and offers easy cleaning. Suitable solution for storage and movement of loads within all segments of the industry and commerce. Ideal for storing food bags where sanitary requirements do not allow direct contact with the floor. It has entries on all four sides for forklift fork access. Metal reinforcements on the feet provide more resistance for use in racks. It features non-slip edges on the top, preventing the load from slipping off the pallet.

APPLICATIONS:

Product storage
 Distribution centers in the pharmaceutical industry
 Supermarkets
 Cold storage facilities
 Rack storage in distribution centers

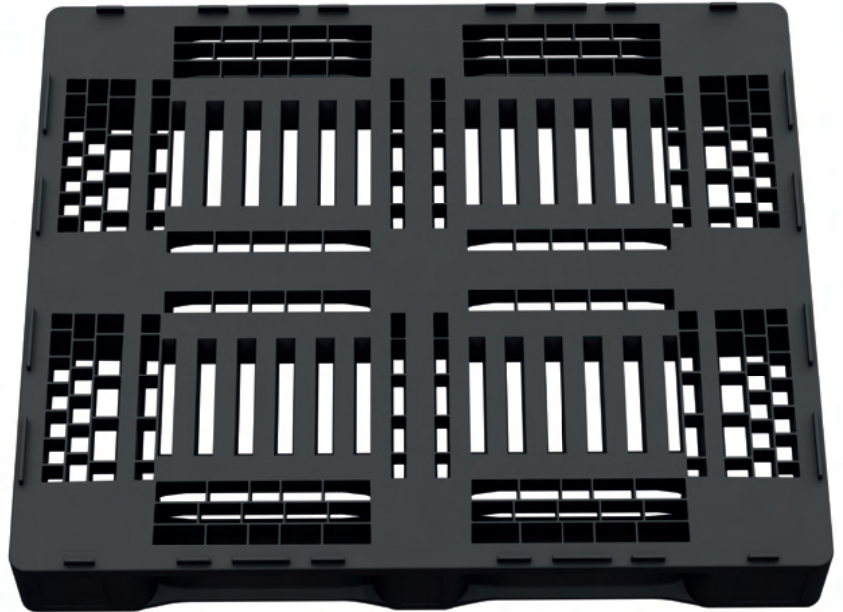

SAFETY EDGE

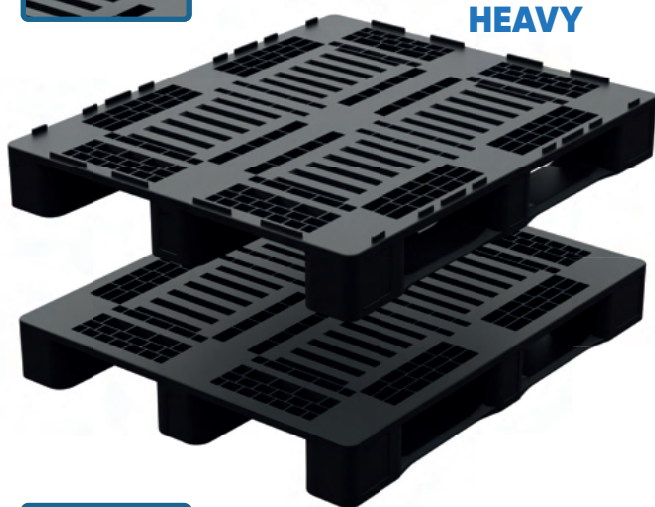

HEAVY



WITHOUT BORDERS



LIGHT

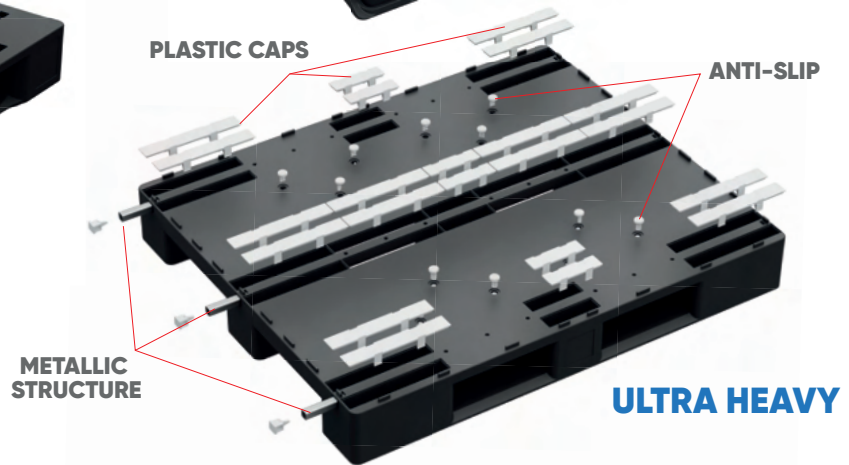

PLASTIC CAPS

ANTI-SLIP

METALLIC STRUCTURE

ULTRA HEAVY

HEAVY STANDARD

WITHOUT SAFETY EDGE

ULTRA HEAVY

LIGHT

COVER

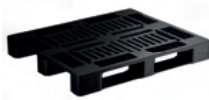

PALLET LINE	NOMINAL DIMENSIONS length x width x height (in)	EXTERNAL DIMENSIONS length x width x height (in)	HEIGHT (in)	STATIC LOAD (lbs)	DYNAMIC LOAD Longitudinal (47,24in) lbs	DYNAMIC LOAD Transversal (39,37in) lbs	PALLET HOLDER LOADING Longitudinal (47,24in) lbs	PALLET HOLDER LOADING Transversal (39,37in) lbs	MATERIAL
HEAVY WITHOUT SAFETY EDGE	47,24x39,37x5,91	47,24x39,37x5,91	6,18	11023	3430	3869	1812	930	PP
HEAVY STANDARD	47,24x39,37x5,91	47,24x39,37x5,91	5,91	11023	3430	3869	1812	930	PP
LIGHT	47,24x39,37x6,18	47,24x39,37x6,18	6,18	2204	881	NA	462	639	PP
ULTRA HEAVY	47,24x39,37x5,91	47,24x39,37x5,91	5,91	17637	3430	5511,56	3306,93	930	PP

Line DOLLIE

FEATURES:

Ideal for transporting heavy boxes, streamlining the entire process by carrying multiple boxes at once with minimal effort.

APPLICATIONS:

Box handling in the distribution center



KLT, TOTE and F-KLT

DOLLIE ALC



DOLLIE LINE	NOMINAL DIMENSIONS length x width x height (in)	WEIGHT (lbs)	CAPACITY (lbs)	MATERIAL
DOLLIE ALC	23,62x15,75x6,69	8,3	529	PP
KLT AND EURO	23,62x15,75x6,69	8,3	529	PP

Line BASKET

FEATURES:

This basket allows for a 65% volume reduction in return stacking. It is easily cleaned and sterilized. It can be customized and offered in various colors, and three versions.

APPLICATIONS:

Supermarket and retail in general

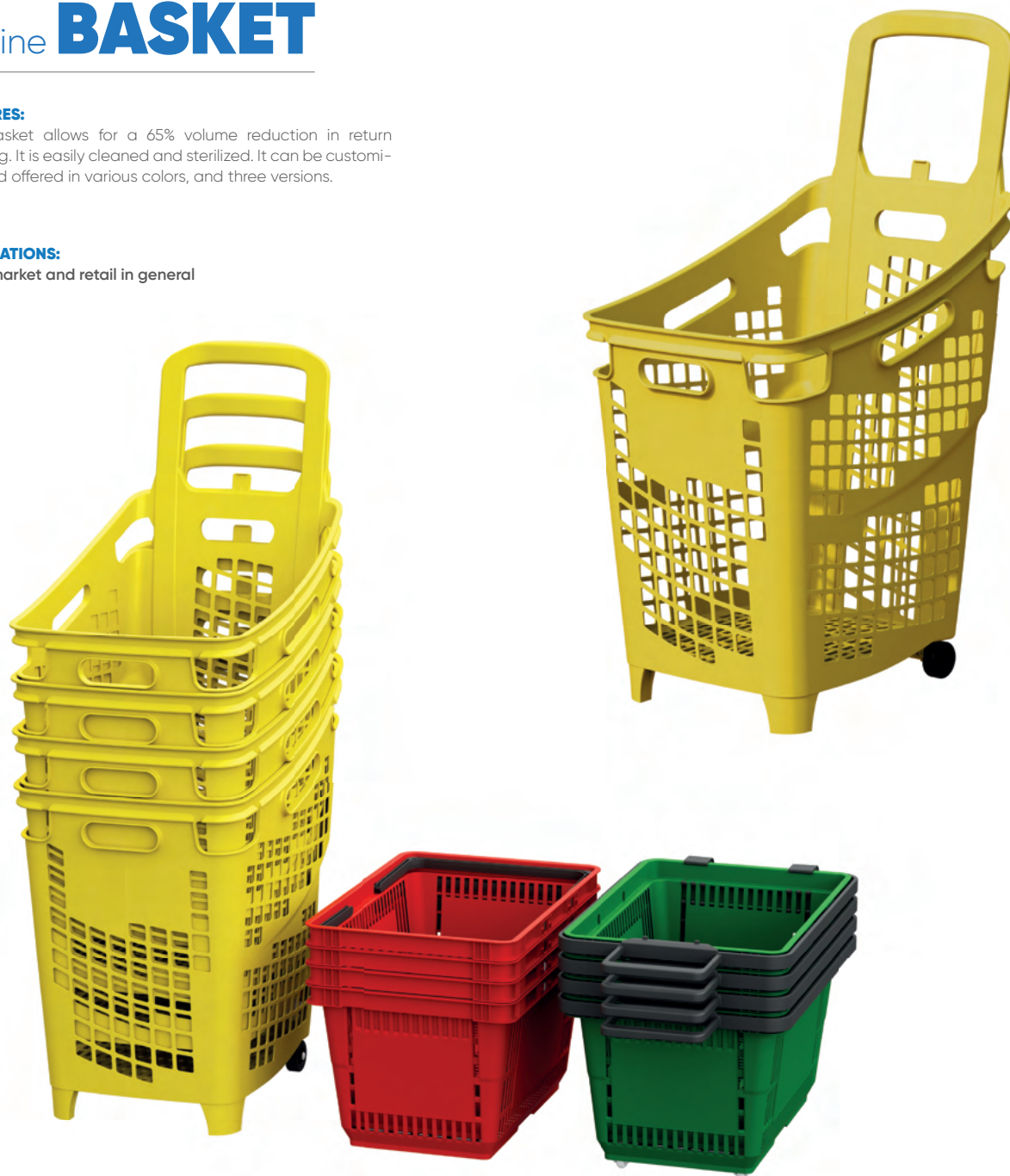

HAND BASKET



CART



LONG BASKET



BASKET LINE	NOMINAL DIMENSIONS length x width x height (in)	EXTERNAL DIMENSIONS length x width x height (in)	INTERNAL DIMENSIONS TOP length x width (in)	INTERNAL DIMENSIONS BASE length x width (in)	USEFUL INTERNAL HEIGHT DIMENSIONS (in)	WEIGHT (lbs)	CAPACITY (ft ³)	MATERIAL
HAND BASKET	18,90x12,60x10,24	18,98x12,87x10,24	17,13x11,14	14,57x8,54	3,58	1,6	0,78	PP
CART	18,90x12,60x10,24	18,98x12,87x10,24	17,13x11,14	14,57x8,54	3,58	2,1	0,78	PP
LONG BASKET	23,62x15,75x35,43	22x15,47x35	18,03x14,41	14,17x12,48	17,28	6,6	2,14	PP

Line **SHELVING UNIT**

FEATURES:

Extremely durable, the HERCULES Shelf supports up to 154 lbs per shelf. Manufactured with thick polypropylene for increased durability, without issues of oxidation and wear. Easy to clean and assemble (no tools required), it features colored sides ideal for Kanban organization, enhancing process management.



**UP TO 154 LBS
PER SHELF**



3 SHELVES

4 SHELVES

5 SHELVES



MODELS	NOMINAL DIMENSIONS length x width x height (in)	WEIGHT (lbs)	CAPACITY (lbs)	MATERIAL
3 SHELVES	35,83x17,72x38,39	15	463	PP
4 SHELVES	35,83x17,72x55,51	19	617	PP
5 SHELVES	35,83x17,72x72,83	26	772	PP

Line TRASH CANS

FEATURES:

The perfect combination of design, robustness, and security. Smart trash cans are equipped with a silent lid that also dampens impact when closing, a safety lock, and a modern and compact design. Available in 3 sizes to meet all major needs.



16 L

25 L

50 L



SIZES	NOMINAL DIMENSIONS length x width x height (in)	WEIGHT (lbs)	CAPACITY (ft ³)	MATERIAL
16 L	12,20x8,27x17,72	2,2	0,57	PP AND POM STEEL
25 L	16,14x11,42x20,08	5,5	0,88	PP AND POM STEEL
50 L	19,29x12,20x24,41	6,6	1,77	PP AND POM STEEL

The MZA experience **ensuring solutions.**

The company MZA Plastic Packaging Solutions is a leader in manufacturing plastic boxes designed for storing, transporting, and handling various products and materials across diverse market sectors. With a wide range of products, we provide solutions for major industries including automotive, food, pharmaceutical, wholesale, industrial, distribution, e-commerce, and more.

Our products play a vital role in company logistics, ensuring safety during transportation, storage, and optimizing reverse logistics processes. We prioritize sustainability and environmental preservation, using plastics that are 100% recyclable.



100% RECYCLABLE

— AND ZERO CARBON PRODUCTS! —





Material Handling Packaging Solutions

innovarr

